

FWD VERSION - 3400 RPM

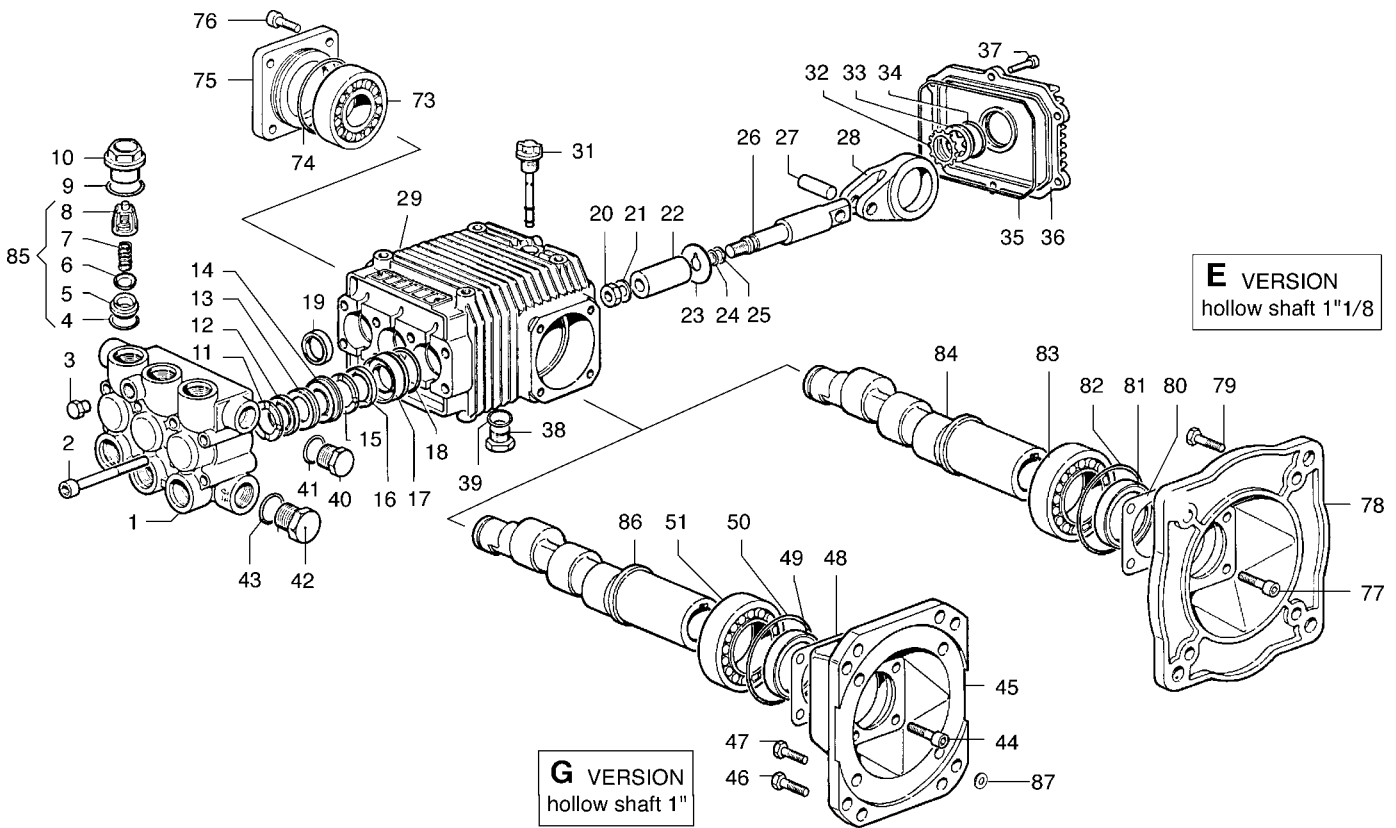

POS. ITEM	CODICE PART No.	KIT KIT	DESCRIZIONE DESCRIPTION	Q.tà Qty.	MODELLI MODELS
1	3218.0110.00		MANIFOLD Ø18 mm	1	
2	3609.0039.00		SCREW M8X70	8	
3	3202.0112.00		CAP 1/4"	1	
4	1210.0046.00	A-D	O-RING 2,62X 17,13 mm	6	
5	3009.0087.00	A	VALVE SEAT	6	
6	3604.0017.00	A	VALVE PLATE	6	
7	1802.0177.00	A	SPRING	6	
8	1205.0025.00	A	VALVE CAGE	6	
9	1210.0048.00	A-D	O-RING 2,62X 20,24 mm	6	
10	3202.0155.00		CAP	6	
11	0009.0199.00	B	HEAD RING Ø18 mm	3	
12	1241.0026.00	B	PACKING 18÷32 mm	3	
13	0009.0100.00	B	PACKING Ø18 mm	3	
14	0009.0200.00		INTERMED. RING Ø18 mm	3	
15	0009.0199.00	B	HEAD RING Ø18 mm	3	
16	1241.0026.00	B	PACKING 18÷32 mm	3	
17	0009.0102.00		PACKING RETAINER Ø18 mm	3	
18	1210.0156.00	B-D	O-RING 1,78X31,47 mm	3	
19	0019.0066.00	D	OIL SEAL 20X30X5 mm	3	
20	0600.0054.00	C	NUT	3	
21	2811.0082.00	C	WASHER 8,2X17X1,5 mm	3	
22	0202.0022.00	C	PISTON Ø18 mm	3	
23	2812.0042.00	C	WASHER	3	
24	1210.0039.00	C-D	O-RING 1,78X 7,66 mm	3	

POS. ITEM	CODICE PART No.	KIT KIT	DESCRIZIONE DESCRIPTION	Q.tà Qty.	MODELLI MODELS
25	0009.0170.00	C-D	ANTI-EXTR. RING	3	
26	2409.0048.00		PISTON GUIDES	3	
27	3011.0016.00		WRIST. PIN Ø10X29 mm	3	
28	0205.0044.00		CON. ROD	3	
29	0403.0130.00		CRANKCASE	1	
31	3200.0051.00		OIL DIPSTICK	1	
32	3019.0033.00		SNAP RING Ø18 mm	1	
33	3201.0012.00		OIL INDICATOR	1	
34	1210.0333.00	D	O-RING 1,78X23,52 mm	1	
35	1210.0216.00	D	O-RING 2,62X107,62 mm	1	
36	0402.0169.00		CRANKCASE COVER	1	
37	3609.0030.00		SCREW M5X20	6	
38	3200.0007.00		CAP 3/8 GAS	2	
39	1210.0093.00	D	O-RING 1,78X 14 mm	1	
40	3200.0007.00		CAP 3/8 GAS	2	
41	2811.0084.00		WASHER 16,7X22X1,5 mm	1	
42	3202.0015.00		CAP G1/2	1	
43	2811.0086.00		WASHER 21,2X27X1,5 mm	1	
44	0440.0012.00		ROLLER BEARING	1	
45	1210.0388.00	D	O-RING	1	
46	0402.0171.00		FLANGE	1	
47	3609.0032.00		SCREW M6X20	4	
48	1220.0030.00		VALVE ASS.BLY	6	

FWD VERSION - 3400 RPM

G version (albero femmina / hollow shaft 1")

POS. ITEM	CODICE PART No.	KIT KIT	DESCRIZIONE DESCRIPTION	Q.tà Qty.	MODELLI MODELS
44	3609.0058.00		SCREW M8X22	4	
45	3016.0013.00		FLANGE	1	
46	3607.0168.00		SCREW 3/8"16X1"	4	
47	3607.0119.00		SCREW 5/16"24X1"	4	
48	0601.0210.00		SHIM Ø68 0,05 mm	1	
	0601.0212.00		SHIM Ø68 0,10 mm	1	
	0601.0214.00		SHIM Ø68 0,19 mm	1	
	0601.0216.00		SHIM Ø68 0,25 mm	1	
49	0019.0052.00	D	OIL SEAL 40X52X7 mm	1	
50	1210.0109.00	D	O-RING 1,78X 63,22 mm	1	
51	0440.0011.00		ROLLER BEARING 40X68X19	1	
86	0001.0329.00		CRANKSHAFT 1"	1	4020 G - 4030 G
	0001.0330.00		CRANKSHAFT 1"	1	4517 G - 4525 G 4530 G
	0001.0350.00		CRANKSHAFT 1"	1	3522 G - 3530 G
	0001.0351.00		CRANKSHAFT 1"	1	5513 G
87	2811.0098.00		WASHER 10,5X18X2 mm	4	

E version (albero femmina / hollow shaft 1" 1/8)

POS. ITEM	CODICE PART No.	KIT KIT	DESCRIZIONE DESCRIPTION	Q.tà Qty.	MODELLI MODELS
77	3609.0058.00		SCREW M8X22	4	
78	3016.0017.00		FLANGE	1	
79	3607.0201.00		SCREW 1/2"-13	4	
80	0601.0210.00		SPACER Ø68 mm	1	
	0601.0212.00		SPACER Ø68 mm	1	
	0601.0214.00		SPACER Ø68 mm	1	
	0601.0216.00		SPACER Ø68 mm	1	
81	0019.0052.00	D	OIL SEAL 40X52X7 mm	1	
82	1210.0109.00	D	O-RING 1,78X 63,22 mm	1	
83	0440.0011.00		ROLLER BEARING	1	
84	0001.0354.00		CRANKSHAFT 1"1/8"	1	4020 E - 4030 E
	0001.0364.00		CRANKSHAFT 1"1/8"	1	3522 E - 3530 E
	0001.0392.00		CRANKSHAFT 1"1/8"	1	4530 E

KIT VALVOLA ASP.-MAND. COMPLETE VALVE KIT 5025.0011.00

KIT A

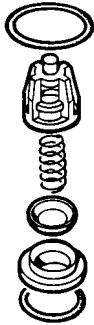

5025.0011.00

POS. ITEM	CODICE PART No.	Q.tà Qty.
4	1210.0046.00	6
5	3009.0087.00	6
6	3604.0017.00	6
7	1802.0177.00	6
8	1205.0025.00	6
9	1210.0048.00	6

KIT GUARNIZIONI PISTONE / PISTON SEAL KIT Ø 18 mm 5019.0038.00

KIT B

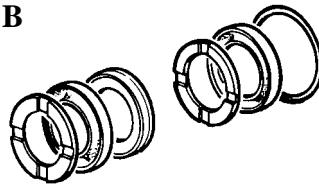

5019.0038.00

POS. ITEM	CODICE PART No.	Q.tà Qty.
11	0009.0199.00	3
12	1241.0026.00	3
13	0009.0100.00	3
15	0009.0199.00	3
16	1241.0026.00	3
18	1210.0156.00	3

KIT PISTONE / PISTON KIT Ø 18 mm 2409.0073.00

KIT C

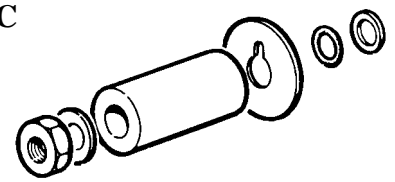

2409.0073.00

POS. ITEM	CODICE PART No.	Q.tà Qty.
20	0600.0054.00	3
21	2811.0082.00	3
22	0202.0022.00	3
23	2812.0042.00	3
24	1210.0039.00	3
25	0009.0170.00	3

KIT GUARNIZIONI POMPA / SEAL KIT ALBERO FEMMINA / HOLLOW SHAFT 5019.0045.00

KIT D

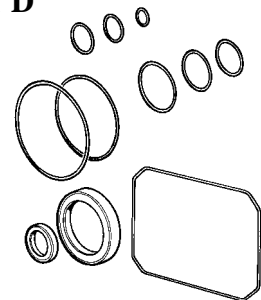

5019.0045.00

POS. ITEM	CODICE PART No.	Q.tà Qty.
4	1210.0046.00	6
9	1210.0048.00	6
18	1210.0156.00	3
19	0019.0066.00	3
24	1210.0039.00	3
25	0009.0170.00	3
34	1210.0333.00	1
35	1210.0216.00	1
39	1210.0093.00	1
74	1210.0388.00	1
49-81	0019.0052.00	1
50-82	1210.0109.00	1

Altri KIT
Other KITS

vedi pagine:
see pages:
54 - 55

FWD VERSION - ALBERO FEMMINA / HOLLOW SHAFT 3/4" - 3400 RPM

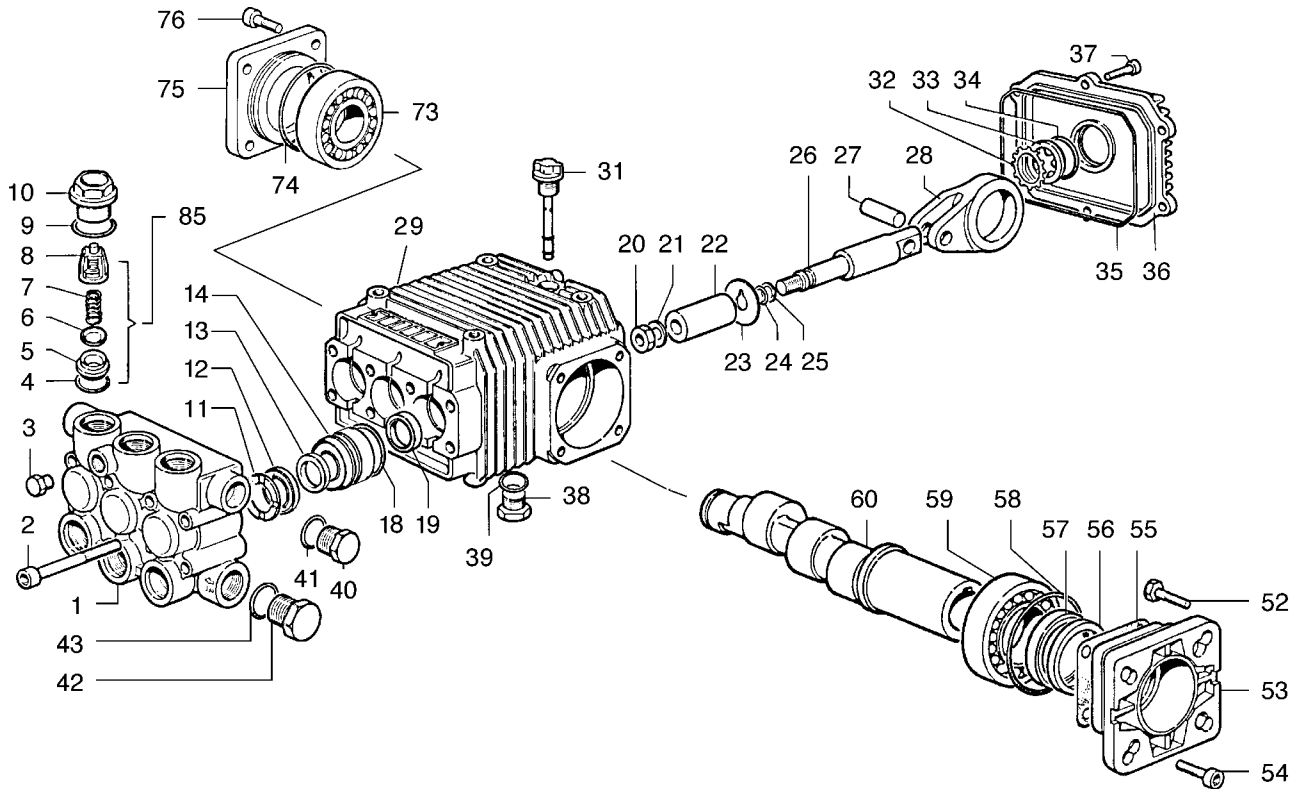

G VERSION
hollow shaft 3/4"

G version solo / only 5513 (albero femmina / hollow shaft 3/4")

POS. ITEM	CODICE PART No.	KIT KIT	DESCRIZIONE DESCRIPTION	Q.tà Qty.	MODELLI MODELS
1	3218.0110.00		MANIFOLD Ø 18 mm	1	
2	3609.0039.00		SCREW M8X70	8	
3	3202.0112.00		CAP 1/4"	1	
4	1210.0046.00	A-D	O-RING 2,62X 17,13 mm	6	
5	3009.0087.00	A	VALVE SEAT	6	
6	3604.0017.00	A	VALVE PLATE	6	
7	1802.0177.00	A	SPRING	6	
8	1205.0025.00	A	VALVE CAGE	6	
9	1210.0048.00	A-D	O-RING 2,62X 20,24 mm	6	
10	3202.0155.00		CAP	6	
11	0009.0199.00	B	HEAD RING Ø18 mm	3	
12	1241.0038.00	B	PACKING Ø18 mm	3	
13	1241.0028.00	B	PACKING Ø18 mm	3	
14	0009.0231.00		PACKING RETAINER Ø18 mm	3	
18	1210.0156.00	B-D	O-RING 1,78X31,47 mm	3	
19	0019.0066.00	D	OIL SEAL 20X30X5 mm	3	
20	0600.0054.00	C	NUT	3	
21	2811.0082.00	C	WASHER 8,2X17X1,5 mm	3	
22	0202.0022.00	C	PISTON Ø18 mm	3	
23	2812.0042.00	C	WASHER	3	
24	1210.0039.00	C-D	O-RING 1,78X 7,66 mm	3	
25	0009.0170.00	C-D	ANTI-EXTR. RING	3	
26	2409.0048.00		PISTON GUIDES	3	
27	3011.0016.00		WRIST. PIN Ø10X29 mm	3	
28	0205.0044.00		CON. ROD	3	
29	0403.0129.00		CRANKCASE	1	

G version solo / only 5513 (albero femmina / hollow shaft 3/4")

POS. ITEM	CODICE PART No.	KIT KIT	DESCRIZIONE DESCRIPTION	Q.tà Qty.	MODELLI MODELS
31	3200.0051.00		OIL DIPSTICK	1	
32	3019.0033.00		SNAP RING Ø18 mm	1	
33	3201.0012.00		OIL INDICATOR	1	
34	1210.0333.00	D	O-RING 1,78X23,52 mm	1	
35	1210.0216.00	D	O-RING 2,62X107,62 mm	1	
36	0402.0169.00		CRANKCASE COVER	1	
37	3609.0030.00		SCREW M5X20	6	
38	3200.0007.00		CAP 3/8 GAS	2	
39	1210.0441.00	D	O-RING 1,78X 14 mm	1	
40	3200.0007.00		CAP 3/8 GAS	2	
41	2811.0084.00		WASHER 16,7X22X1,5 mm	1	
42	3202.0015.00		CAP G1/2	1	
43	2811.0086.00		WASHER 21,2X27X1,5 mm	1	
52	3607.0199.00		SCREW 5/16"24X3/4"	4	
53	3016.0020.00		FLANGE	1	
54	3609.0032.00		SCREW M6X20	4	
55	0601.0218.00		SHIM Ø62 0,05 mm	1	
	0601.0220.00		SHIM Ø62 0,10 mm	1	
	0601.0222.00		SHIM Ø62 0,19 mm	1	
	0601.0259.00		SHIM Ø62 0,25 mm	1	
56	0019.0096.00	D	OIL SEAL 35X52X7 mm	1	
57	0601.0262.00		SPACER	1	
58	1210.0388.00	D	O-RING	1	
59	0440.0018.00		ROLLER BEARING	1	
60	0001.0371.00		CRANKSHAFT 3/4"	1	

FWD VERSION - ALBERO FEMMINA / HOLLOW SHAFT 3/4" - 3400 RPM

KIT VALVOLA ASP.-MAND. COMPLETE VALVE KIT 5025.0011.00

KIT A

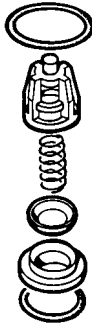

5025.0011.00

POS. ITEM	CODICE PART No.	Q.tà Qty.
4	1210.0046.00	6
5	3009.0087.00	6
6	3604.0017.00	6
7	1802.0177.00	6
8	1205.0025.00	6
9	1210.0048.00	6

KIT GUARNIZIONI PISTONE / PISTON SEAL KIT Ø 18 mm 5019.0067.00

KIT B

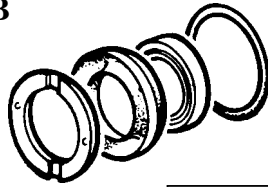

5019.0067.00

POS. ITEM	CODICE PART No.	Q.tà Qty.
11	0009.0199.00	3
12	1241.0038.00	3
13	1241.0028.00	3
18	1210.0156.00	3

KIT PISTONE / PISTON KIT Ø 18 mm 2409.0073.00

KIT C

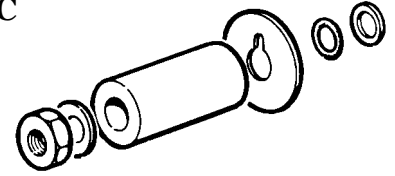

2409.0073.00

POS. ITEM	CODICE PART No.	Q.tà Qty.
20	0600.0054.00	3
21	2811.0082.00	3
22	0202.0022.00	3
23	2812.0042.00	3
24	1210.0039.00	3
25	0009.0170.00	3

KIT GUARNIZIONI POMPA / SEAL KIT ALBERO FEMMINA / HOLLOW SHAFT 5019.0058.00

KIT D

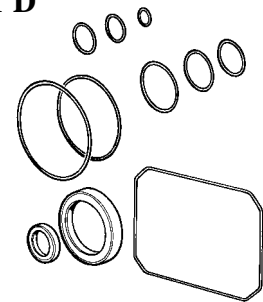

5019.0058.00

POS. ITEM	CODICE PART No.	Q.tà Qty.
4	1210.0046.00	6
9	1210.0048.00	6
18	1210.0156.00	3
19	0019.0066.00	3
24	1210.0039.00	3
25	0009.0170.00	3
34	1210.0333.00	1
35	1210.0216.00	1
39	1210.0441.00	1
56	0019.0096.00	1
74	1210.0221.00	1
58	1210.0388.00	1

Altri KIT
Other KITS

vedi pagine:
see pages:
54 - 55